

# COVAL

vacuum managers

## VACUUM HANDLING SOLUTIONS FOR THE AUTOMOTIVE INDUSTRY



vacuum  
**management**

# ADVANCED VACUUM SOLUTIONS

[www.coval.com](http://www.coval.com)

EN2

## Vacuum Managers

At COVAL our goal is to contribute to the performance and safety of industrial processes by vacuum handling objects of all sizes, weights, and materials.

COVAL has focused our expertise in four complementary areas to achieve this goal:

- The development of technological solutions based on **'just innovation'**
- Manufacturing of vacuum pumps and suction cups in **France**,
- Distribution of the range by our **sales team, 5 subsidiaries, and a network of selected distributors**
- **Service before and after** the launch of the product to: analyze the application, aid in decision making, and train users.

COVAL is a company which shares with its customers its values of **technical know-how, productivity, commitment, flexibility, and responsibility.**

COVAL provides a comprehensive range of vacuum handling services for its customers - that's why COVAL employees are **Vacuum Managers.**

# AUTOMOTIVE

## Faster & Safer

Automotive manufacturers are faced with fast and far-reaching changes. COVAL has been at their side providing support to keep pace with these developments for more than three decades.

Beyond mere products, COVAL delivers comprehensive solutions that measure up to these challenges. We take pride in our ability to analyze, propose, develop, produce, and support the most suitable solution.

We are your **Vacuum Managers** in everything that we do every day.

COVAL provides the various players in the automotive industry with an overall vacuum handling approach for all their lifting, moving, placing, and clamping needs for any parts of the car body, glazing, and accessories. COVAL solutions, such as vacuum pumps and suction cups, can be fitted on robots for presses, welding, assembly, and glass fitting.

The challenges that the automotive industry and its partners raise require technical expertise, know-how, innovation, and dedicated services.

To meet these challenges, COVAL relies on its strengths:

- A sound ability to innovate and deliver
- A team that is fully dedicated to the automotive industry
- A comprehensive range that includes both mechatronics and communication
- Compact vacuum solutions
- Compliance with the most stringent quality standards
- An international presence thanks to our subsidiaries located in all high-potential economic areas.

- Solutions that enable great flexibility and modularity in production.
- Higher performance characteristics combined with greater compactness.
- Solutions that account for developments in materials and machines.
- A single contact point for all vacuum handling solutions.

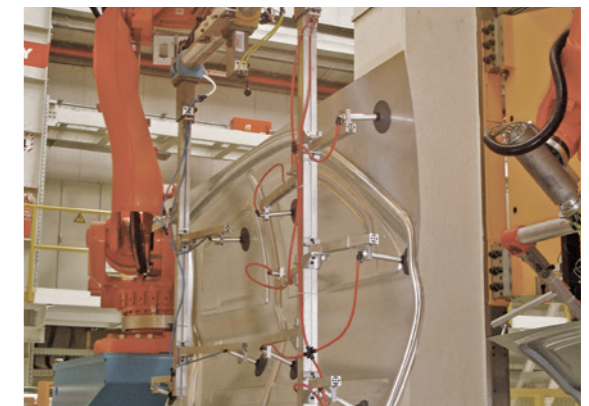

We stand by your side from idea to implementation

AUDIT EXISTING PROCESSES  
MAKE RECOMMENDATIONS



DEVELOP SPECIFIC  
SOLUTIONS



MEASURE  
EFFICIENCY



## Safety, Productivity, and Flexibility at Every Step in Production

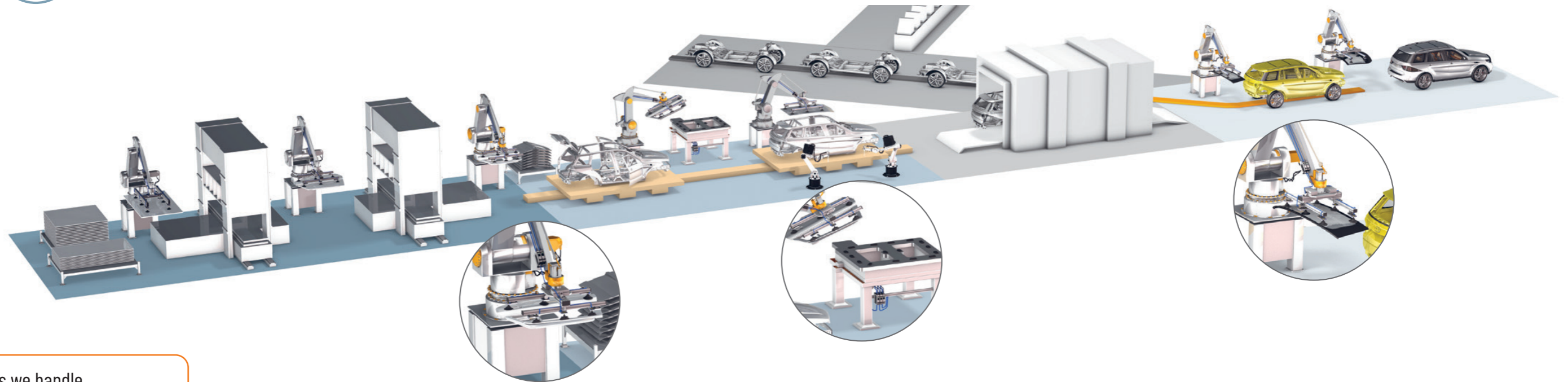

### Materials we handle

- Metals
- Plastics
- Aluminum
- Cured and uncured composite materials
- Glass

### Machines we fit

- Robot cells
- Floor-mounted equipment: crimping, clamping
- Stamping lines
- Assembly lines

### Parts we handle

- Sheet metal
- Stamped parts
- Frame
- Bodywork
- Windshields/quarter glass
- Bumpers
- Doors and hatches
- Plastic parts

### We work with

- Car manufacturers
- Equipment manufacturers
- Subcontractors
- Integrators
- Remove etc.

### Equipment for stamping lines

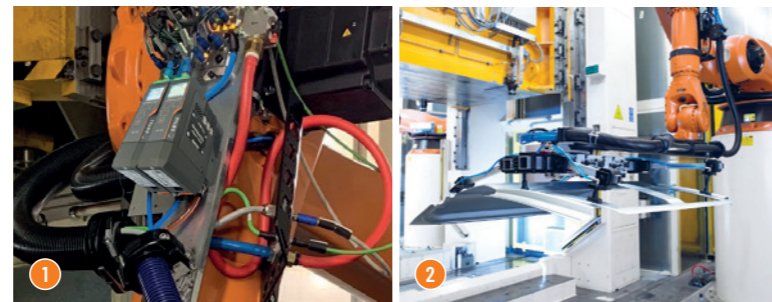

1 2 GVMAX HD vacuum pumps and C-series high-performance suction cups for handling stamped parts.

### Equipment for body assembly lines

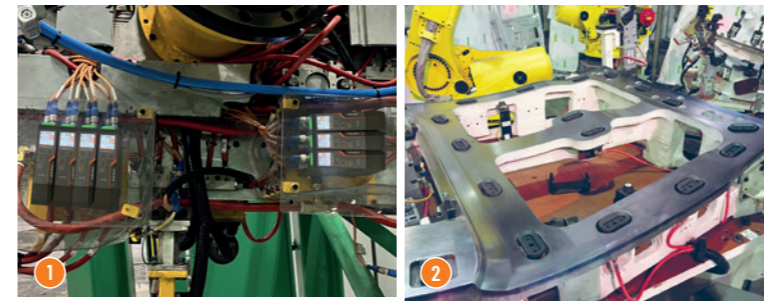

1 GVMAX HD vacuum pumps banked module on robot equipment  
2 C-series high-performance suction cups on floor-mounted equipment (clamping)

### Equipment for final assembly

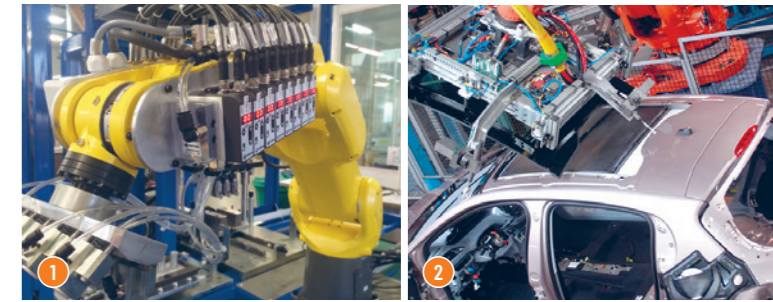

1 LEMAX mini vacuum pump bank on high-speed robot  
2 GVMAX HD vacuum pumps and VPYR ball joint suction cups for handling of glazed elements

### YOUR EXPECTATIONS:

#### Solutions that increase your productivity:

- Reduce cycle times
- Decrease energy costs
- Minimize maintenance
- Adapt quickly to changing workpieces
- Increase equipment lifetime
- Manage equipment from remote locations



### OUR SOLUTIONS:

#### Compact and lightweight vacuum pumps:

- Compact and lightweight "all-in-one" solution with integrated control, vacuum regulation, blow-off air, and "part presence" detection functions
- Vacuum pumps that are able to communicate and fully integrate with the field network without requiring any gateways or other specific interfaces allow the configuration and vacuum control to be managed from a remote location
- **Air Saving Control (ASC)** technology allows for energy savings of up to 90%

- Because they are extremely compact, COVAL vacuum pumps can be installed right next to the suction cups, thus combining energy savings with short response times
- A clog-free open silencer ensures maximum operational capacity

#### High-speed structured suction cups:

- Handle thin metal sheets without deforming them
- Ideal for robotic applications

- Slip prevention stops ensure optimal placement of oiled metal sheets
- Broad range of suction cups in various shapes and sizes for a perfect fit with handled parts

#### Accessories and complementary products:

- COVAL has a wide range of accessories for vacuum networks: extensions, vacuum connections and feeders, vacuum switches, and more

# A comprehensive range and unique technologies closely focused on the Automotive industry's needs

## → Energy efficiency

Using less lowers the environmental impact of production and reduces production costs.

## → Reliability

Eliminating machine downtime for maintenance means increasing Production line productivity.

## → Ergonomics

Accelerate the handling and use of products making operators more versatile.

## → Flexibility

Enabling a product to adapt itself to your production helps provide flexibility and reactivity.

## → Very high output

Combining suction cups and Vacuum Pumps developed specially for very high outputs, to meet the expectations of the most demanding customers.

## → Compact and lightweight

COVAL vacuum pumps integrate, in a reduced size, all necessary functions for an optimized vacuum management. Their reduced size and weight allow the suction cups to be positioned at minimum distance to achieve the shortest possible grip time without load loss.

## → Communication

Communication needs vary depending on the industry and application, but more and more, an efficient and real time communication system allows for increased flexibility of the machine. In addition, the simplification of wiring and configuration is a benefit for integrators, while expanding the possibilities of diagnosis and optimization.

## → ASC (Air Saving Control)

is a regulation system which stops air consumption when the set vacuum level is attained. It provides up to 90% energy savings and a significant reduction in noise level.

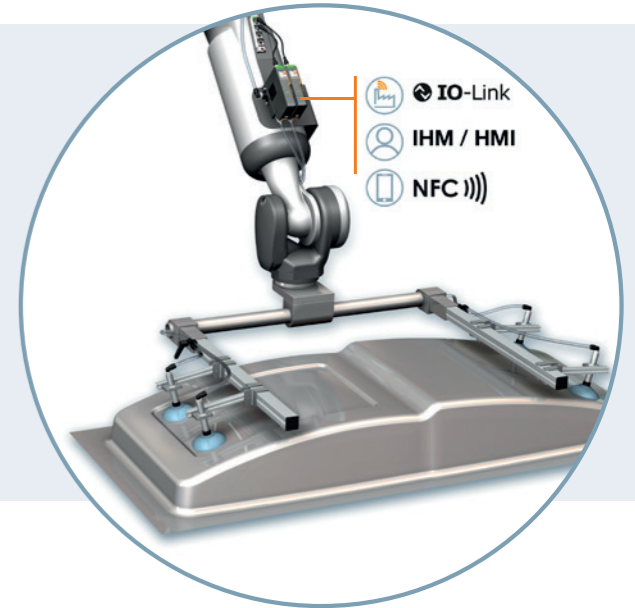

## Suction Cups



### C-series suction cups: CFC, CBC, COFC, COBC

- Structured suction cups for gripping thin-walled parts without deforming them
- Ideal for handling or holding in vertical position
- Slip prevention stops ensure optimal positioning and holding



### High-Performance Bell-type Suction Cups: CTC series

- Excellent adaptation to convex surfaces and angular shapes
- Excellent resistance to wear and oil thanks to thermoplastic polyurethane (TPU)
- Particularly suitable for use on high-speed presses, for high speeds and handling of large parts (e.g. body side, roof, doors)



### Ball joint suction cups: VPYR series

- Flat suction cups with ball joint system
- 4 models available (50 to 100 mm in Ø)
- Materials: nitrile and silicone
- We recommend the ball joint suction cup range for gripping bulging products or rotating products that require a lot of physical and mechanical force



## Vacuum Pumps



### GVMAX HD series

Heavy Duty Communicating Vacuum Pumps with ASC 

- ASC: More than 90% energy savings
- Auto-adaptation depending on the material to be handled
- Suction flow rate up to 8.05 SCFM
- Stand-alone or bankable
- IO-Link or SIO (Standard Inputs Outputs) operation
- High-visibility color display
- IP65/50 million cycles



 IO-Link  
NFC )))

### LEMAX, LEMAX+ and LEMAX IO series

Integrated mini vacuum pumps with ASC 

- ASC: More than 90% energy savings
- Auto-adaptation depending on the material to be handled
- Communication protocol IO-Link (LEMAX IO)
- Handling all airtight or low porosity pieces



 IO-Link

### LEMCOM series

Vacuum pump with fieldbus communication (EtherNet/IP or PROFINET):

- 1 "master" module controls from 1 to 15 secondary modules
- The master module is a full-fledged pump
- Remote configuration, control, and diagnostics: integrated web server, configuration software, and more
- Additional communication port



 EtherNet/IP  
 PROFINET

## Accessories

### L series extensions

- Ensure that the suction cups are fastened
- Make it possible to adjust the position of the suction cup on the tooling
- Guarantee airtightness of the assembly by using a coil fitting with an O-ring



### Vacuum switches

Electronic, electric, or pneumatic  
PSD, PSK, PSA100, PSE, PSP



### Spring systems

1/8G - 1/4G - 3/8G Standard or anti-rotation TS - YS - TSOP - TSOG



### Vacuum filter

1/8G - 1/4G - 3/8G - 3/4G - 2"  
Filtering cartridge:  
paper, stainless steel, or polyamide



### Alarm cabinet

Fully integrated and autonomous pneumatic alarm cabinet

- Pneumatic horn in the event of low or failing compressed air
- Critical threshold value triggering the alarm: 4.5 bar
- For use with pneumatic systems

## Vacuum Grippers



### MVG series

Modular vacuum gripper

- Customized sizes
- Selection of gripping zones
- Compact and lightweight



 IO-Link  
NFC )))

### CVGL series

Vacuum gripper

- Many possible combinations
- Integration of all functions
- Adapted to a large number of industries



 IO-Link  
NFC )))



ANDROID APP ON  
Google play



Download on the  
App Store

You will find our catalog and 3D CAD Models of all our products, on our website [www.coval.com](http://www.coval.com), or via our free downloadable mobile apps.

# COVAL, as close as possible to your production

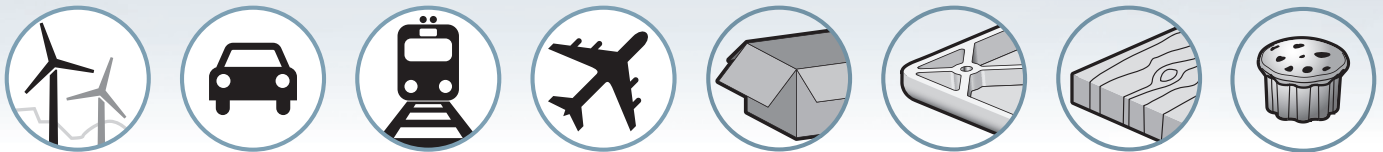

- Factory
- Head office
- Subsidiaries
- Distributors



Distributed by:



certified quality  
management system

**COVAL S.A.S. - Head Office**  
ZA Les Petits Champs  
10 allée Jean-Baptiste Venturi  
26120 Montélier France  
Tel : +33 (0)4 75 59 91 91  
Fax : +33 (0)4 75 59 91 05

[www.coval.com](http://www.coval.com)